

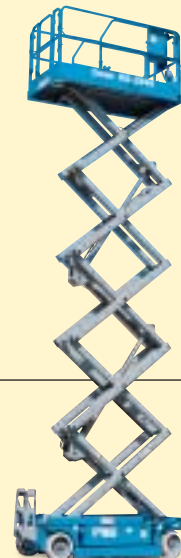

# Electric Self-Propelled Scissor Lift

GS-2046  
GS-2646  
GS-3246

- Satisfies your heavy lifting requirements with ease and efficiency.



**Genie Industries**

GS-2046  
GS-2646  
GS-3246

## GS-2046, GS-2646 and GS-3246

- The solid steel deck platform has a **slip-resistant surface**.
- Heavy duty guardrails fold down quickly without tools for **increased accessibility**.
- **Lubrication-free, service-free pivot points**.
- **Built-in lanyard attachment points** are provided.
- The ergonomic Joystick Controller operates from the platform or the ground.
- **Low noise level** allows

operation in quiet work environments.

- High angle steering provides **excellent maneuverability**.
- Swing-out battery box and power module allow **easy access to components**.
- Variable speed motor **extends battery and motor life** by using only the energy needed to do the required work.

### Standard Features

- 39 in (1 m) roll-out platform extension
- Proportional controls for lift and drive functions
- AC wiring to platform
- Multiple disc brakes provide smooth deceleration
- Manual platform lowering valve
- Tilt sensor with an audible alarm
- Pothole guards
- Emergency stop switches at both platform and ground controls
- Automatic 25 amp battery charger
- Manual brake release
- Non-marking tires
- Hour meter

### Options and Accessories

- Automotive horn
- Motion alarm
- Platform swing gate
- Air line to platform
- Dual flashing beacons
- Power inverter
- Maintenance-free battery

### Standards Compliance

- ANSI/SIA A92.6
- CSA CAN3-B354.2-M82
- CE compliance option
- AS 1418.10

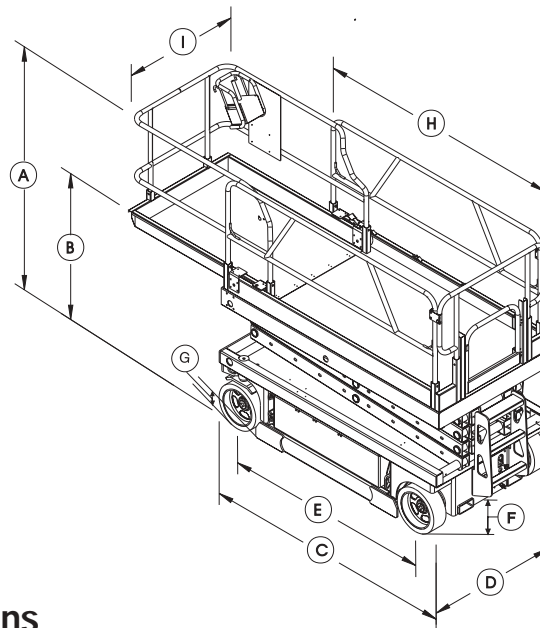

### Specifications

Model	GS-2046		GS-2646		GS-3246	
	US	Metric	US	Metric	US	Metric
Working height*	26 ft	8.1 m	32 ft	9.9 m	38 ft	11.75 m
Platform height	20 ft	6.1 m	26 ft	7.9 m	32 ft	9.75 m
Ⓐ Height - stowed (guardrails folded)	64 1/2 in	1.64 m	68 in	1.73 m	73 1/4 in	1.86 m
Height - stowed (guardrails)	86 in	2.18 m	89 3/4 in	2.28 m	94 7/8 in	2.4 m
Ⓑ Height - stowed (platform)	41 in	1.04 m	46 in	1.17 m	51 1/4 in	1.3 m
Ⓒ Length - stowed	96 in	2.44 m	96 in	2.44 m	96 in	2.44 m
Ⓓ Width	46 in	1.17 m	46 in	1.17 m	46 in	1.17 m
Ⓔ Wheelbase	73 in	1.85 m	73 in	1.85 m	73 in	1.85 m
Ⓕ Ground clearance - at machine center	4 in	10 cm	4 in	10 cm	4 in	10 cm
Ⓖ Ground clearance - pothole guards deployed	7/8 in	2 cm	7/8 in	2 cm	7/8 in	2 cm
Ⓗ Platform length-stowed	89 in	2.26 m	89 in	2.26 m	89 in	2.26 m
Platform length-extended	128 in	3.25 m	128 in	3.25 m	128 in	3.25 m
Ⓛ Platform width	45 5/8 in	1.16 m	45 5/8 in	1.16 m	45 5/8 in	1.16 m
Roll-out platform extension	39 in	1 m	39 in	1 m	39 in	1 m
Lift capacity ANSI, CE	1,200 lb	544 kg	1,000 lb	454 kg	700 lb	318 kg
CSA	1,200 lb	544 kg	1,000 lb	454 kg	500 lb	227 kg
Extension deck lift capacity	250 lb	113 kg	250 lb	113 kg	250 lb	113 kg
Turning radius outside	92 in	2.34 m	92 in	2.34 m	92 in	2.34 m
Turning radius inside	zero		zero		zero	
Power source	24V (4 6V 245AH batteries) (all models)					
Drive speed - stowed	2.2 mph	3.5 km/h	2.2 mph	3.5 km/h	2.2 mph	3.5 km/h
Drive speed - raised	0.5 mph	0.8 km/h	0.5 mph	0.8 km/h	0.5 mph	0.8 km/h
Raise/lower speed	30/28 sec		30/24 sec		57/40 sec	
Controls	proportional		proportional		proportional	
Tires (solid rubber)	15x5x11 in 38x13x28 cm (all models)					
Gradeability	30%	30%	30%	30%	25%	25%
Drive	dual front wheel		dual front wheel		dual front wheel	
Multiple disc brakes	dual rear wheel		dual rear wheel		dual rear wheel	
Weight	4,324 lb	1,961 kg	4,646 lb	2,107 kg	6,172 lb	2,800 kg

\*The metric equivalent of working height adds 2 m to platform height. U.S. adds 6 ft to platform height.

Distributed By:

**Genie Industries**

#### GENIE UNITED STATES

18340 NE 76th Street  
P.O. Box 97030  
Redmond, Washington 98073-9730  
Telephone (425) 881-1800  
Toll Free in USA/Canada 800-536-1800  
Fax (425) 883-3475  
http://www.genieindustries.com

#### GENIE UNITED KINGDOM

The Maltings, Wharf Road  
Grantham  
Lincolnshire NG31 6BH  
England  
Telephone: +44 (0)1476 584333  
Fax: +44 (0)1476 584334  
http://www.genieindustries.com

For further information, please contact your local distributor or the Genie sales office listed. Continuous improvement of our products is a Genie policy. Product specifications are subject to change without notice or obligation. The photographs and drawings in this brochure are for illustrative purposes only. Refer to the appropriate Genie GS-2046, GS-2646 and GS-3246 Operator's Manual for instructions on the proper use of this equipment. Failure to follow the appropriate Operator's Manual when using a Genie GS-2046, GS-2646 or GS-3246 or to otherwise act irresponsibly, may result in serious injury or death. Copyright © 1997 by Genie Industries. Printed in the U.S.A. on recyclable paper. "Genie" is a Registered Trademark of Genie Industries in the USA and many other countries.

\*GS\* is a Trademark of Genie Industries. Genie is the owner of US Patent 6,050,358 and other Patents Pending. GS46 6.5K 0503I. Part No. 65033